

INSTRUCTION MANUAL

TEMPERATURE SENSOR TGL DS 18B20

The temperature sensor with a cable for measuring temperatures of gaseous and liquid substances ranging from -40°C to 105°C intended for universal application.



SENSIT s.r.o.

Školní 2610, 756 61 Rožnov pod Radhoštěm, ID No. 64087484, VAT No. CZ64087484, Phone: +420 571 625 571, Fax: +420 571 625 572
Company is incorporated in the Companies Register at the Regional Court in Ostrava, Section C, File 13728, sensit@sensit.cz, www.sensit.cz



2554.1	10-20
Supersede	

Legal regulations and standards:

- Electrical connection of the detector may only be carried out by a competent person with electrician qualification who is familiarized with the "Instruction Manual" in detail.
- The Instruction Manual is part of the product and it is necessary to keep it for the entire service life of the product.
- The Instruction Manual must be transferred to any other owner or user of the product.
- The disposal must be performed in compliance with the Directive 2008/98/EC of the European Parliament and of the Council - on waste and the Directive 2012/19/EU of the European Parliament and of the Council – on waste electrical and electronic equipment (WEEE), as amended.
- The sensors are delivered in packages, which guarantee resistance to mechanical influences and that meet the conditions with the European Parliament and Council Directive 94/62/EC on packaging and packaging waste), as amended.
- The final metrological inspection – comparison with standards or working instruments – is carried out for all the products. Continuity of the standards and working measuring instruments is ensured within the meaning of the Section 5 of Act no.505/1990 on metrology. The manufacturer offers a possibility to supply the sensors calibrated in SENSIT s.r.o. laboratory (according to EN ISO/IEC 17025 standard) or in an Accredited laboratory.

Application:

The temperature sensors TGL are designed for measuring temperatures of gaseous and liquid substances. The temperature range for application of the sensor is -40°C to 105 °C and it must not be exceeded even for a short term. The sensors may be used for all control systems compatible with the DS 18B20 temperature sensor. They meet the ingress protection IP67 according to the EN 60 529 standard. The temperature sensors are designed for universal application. The sensors in combination with JTG8 thermowell can be used for measuring temperatures in piping. The sensors are suitable for temperature measurement in chemically non-aggressive environments, the using must be chosen regarding temperature and chemical resistant housing and a cable.

Recommended use and location of sensors:

- Operating position is arbitrary
- Sensor must be placed into protective thermowell for continuous temperature measurements of liquid substances
- For measure the temperature of liquid and gaseous substances is recommended the minimum immersion of the sensor in the medium --- 80 mm
- If the sensor with thermowell is placed in the pipeline behind the pipe mixer, a minimum distance between the sensor and the mixer corresponding to tenfold of pipe diameter has to be observed.
- If the stem is longer than pipe diameter, the sensor is recommended to install at an angle or into a pipe bypass

Warnings and restrictions:

The sensors must not be used for measuring in locations:

- Where the specified technical parameters and operating conditions are not adhered
- Where the sensor is exposed to mechanical action
- With explosion hazard
- For measuring temperatures of subjects under voltage
- With chemically aggressive environment
- Where the sensor is exposed to permanent immersion in the liquid

It is not suitable to use the sensors for measuring temperature in locations:

- Where sufficient contact with the measured fluid is not secured (low submersion of the sensor, effects of the surroundings).
- Where the supply cable might run parallel to mains cables (risk of interference signal induction and the measurement results may be influenced), the safe distance from mains power cables when cables run parallel can be as much as 0,5 m according to the nature of interfering fields.
- Where the sensor might be exposed to effects of strong organic and inorganic acids with medium and strong concentrations at high temperatures, weak organic acids with high concentrations and high temperatures, chlorinated hydrocarbons, and undiluted alkaline substances.

Failure to follow the said recommendations will negatively affect measurement accuracy, reliability and service life of the temperature sensor.

Declaration of conformity

SENSIT s.r.o. provides the product with the **EU Declaration of Conformity** issued according to Act No. 22/1997 Coll., as subsequently amended. The product is in accordance with the following directives:

- European Parliament and Council Directive 2011/65/EU of 8 June 2011 on the restriction of the use of certain hazardous substances in electrical and electronic equipment and Commission delegated Directive 2015/863/EU of 31 March 2015 amending annex II to Directive 2011/65/EU, as amended

Product safety:

Product safety and technical parameters were evaluated according to the following standards and norms, as amended:

- EN 60730-1, EN 60730-2-9
- EN 60751, EN 60 529

Sensor description:

The sensor consists of a metallic housing with the sensing element inside and a supply cable. The sensor housing is made of stainless steel. The sensors is connected as three-wire, the DQ signal is connected by two wires. The supply cable has external PVC insulation and is unshielded. The length of housing is 40mm (optionaly 60 or 100 mm).

Sensor installation:

1. If the sensor is used in combination with the thermowell, screw the thermowell in the welded-on piece on the piping or in the specific threaded location.
2. Install the sensor in the measured location or insert it in the thermowell and ensure fix installation of the sensor to prevent its movement
3. Connect the wires of the supply cable to the evaluation unit according the wiring diagram.
4. After installation and connection to the consequential electrical measuring device, the sensor is ready for operation. The sensor does not require any special manipulation or maintenance.

Wiring diagram:

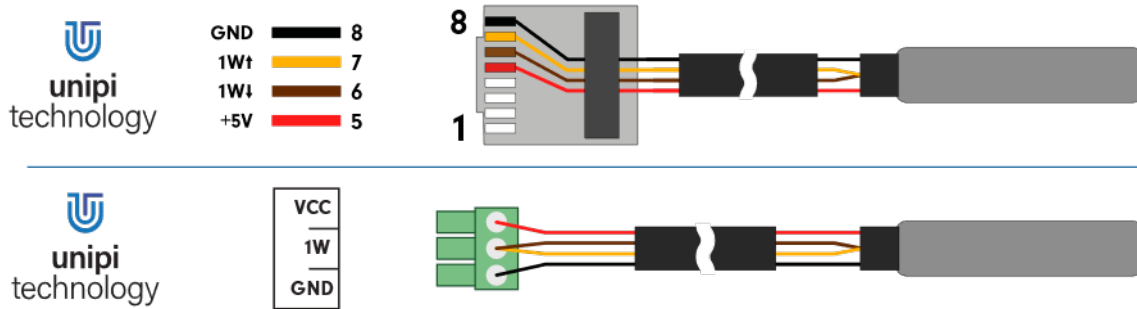

Technical parameters:

Type of element	Dallas DS18B20
Accuracy class of element	$\pm 0,5^{\circ}\text{C}$ in range -10 to 80°C
Temperature element wiring	Three – wire, 2x signal DQ
Measuring range	-40°C to 105°C
Power supply	3 to 5V SELV or PELV
Sensor IP code	IP 67 according to EN 60 529
Response time	$\tau_{0,5} < 7$ sec (in flowing water $> 0,2$ m.s ⁻¹)
Housing material	40, 50, 60 mm: stainless steel DIN 1.4571 Others length: stainless steel DIN 1.4301
Housing diameter	$5.7 \pm 0,1$ mm
Housing length	
Dielectric strength	500 VAC according to EN 60730-1
Insulation resistance	> 200 M Ω at 500VDC, $25 \pm 3^{\circ}\text{C}$
Supply cable type	PVC unshielded 4 x AWG26
Supply cable length	
Pressure resistance (Effect on the stem with the medium)	Without thermowell 2,5 MPa With thermowell 6,3 MPa
Weight	0,05 kg for length 40 mm and cable 1 m

Operating conditions:

- temperature round the supply cable: -40 °C to 105 °C
- relative humidity of the surroundings: 10 to 100 %
- atmospheric pressure: 70 to 106 kPa
- Maximum water flow speed and speed of air when measuring temperature in piping with thermowell:

The length of the stem (mm)	up to 60	> 60 to 100	> 100 to 160	> 160 to 220	> 220 to 400
Speed water flow	2 m.s ⁻¹	1,5 m.s ⁻¹	1 m.s ⁻¹	0,6 m.s ⁻¹	0,3 m.s ⁻¹
Speed of air	20 m.s ⁻¹	15 m.s ⁻¹	8 m.s ⁻¹	2,5 m.s ⁻¹	0,6 m.s ⁻¹

Storage:

- Ambient temperature 5 to 40 °C
- Humidity 5 to 85%

Delivery:

Each delivery contains the following unless otherwise agreed by the customer:

- Sensor according to purchase order
- Instruction Manual, including Guarantee Certificate
- Delivery Note

Complaints and repairs:

Guarantee and after-guarantee repairs of sensors are ensured by the manufacturer. The product must be delivered including a copy of the Guarantee Certificate, duly packed and fit to shipment so as not to get damaged during transportation.

GUARANTEE CERTIFICATE

The product is covered by guarantee for 24 months from the date of purchase.

In this period, the manufacturer will remove all material or manufacturing defects arisen demonstrably during the applicable warranty period. The manufacturer is liable for the technical and operational parameters of the product given in the user manual. Any identified defects will be claimed by the buyer without undue delay after their identification or, as appropriate, after the buyer was able to identify them during his routine care. A completed Warranty Certificate with a brief description of the defect plus the product must be submitted with the claim.

Warranty does not cover a product:

- That was damaged during transport and inappropriate storage, improper commissioning and/or that has been used for a purpose other than specified
- That has been used in an improper manner, inconsistent with the user manual and/or generally applicable technical standards or safety regulations
- That is worn or damaged as a result of normal use of the product, without loss of its operational characteristics and guaranteed technical parameters
- Into which unskilled intervention, unauthorised structural or other changes (reprogramming, resetting of set parameters, etc.) have been made
- That is mechanically damaged, e.g. by fall, being hit by a hard object, cleaning with unsuitable agents, power cord tearing/breaking, breaking or other damage of individual product parts
- That has been exposed to adverse external influence, e.g. object intrusion, wrong supply voltage, influence of chemical processes, electrical surge (obviously burnt components or printed circuits), dusty, dirty, aggressive or otherwise unsuitable environment, except normal variation
- That has been damaged by an incidental or natural disaster or as a result of natural or external phenomena, such as storm, fire, water, excessive heat
- That is claimed without the Warranty Certificate or nameplate.

Rights and obligations regarding the rights arising from defective performance will be governed by the applicable legislations and the applicable Business Terms and Conditions of SENSIT s.r.o. and this Warranty Certificate.

Date of sale confirmation:**Serial number:**